



BY JOHNSON CONTROLS

070-510 SPC (MAY 2010)

## SPECIFICATIONS

File: EQUIPMENT MANUAL - Section 70  
Replaces: E70-510 SPC (JAN 2005)  
Dist: 10

# ROTARY SCREW COMPRESSORS

## Models XJF/XJS 95 through 151



XJF

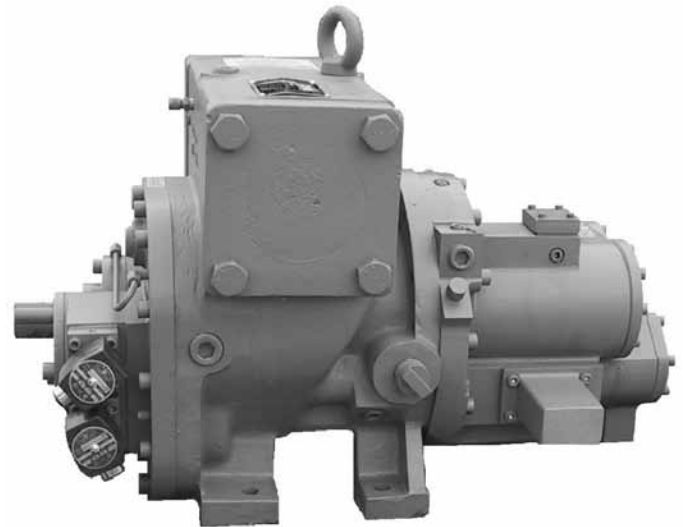

XJS

### SPECIFICATIONS

The Frick® XJS/XJF screw compressor is designed to compress a variety of gases in many different applications including refrigeration, air conditioning, water chilling, wellhead compression, gas gathering, and vapor recovery. Applications include booster duty (low temperature/pressure), high (single) stage, or swing duty compression.

**Stepless Capacity Control** - A hydraulically or manually actuated slide valve moves axially along the rotor mesh line to provide unloading down to 25% of full load capacity. Unloaded gas is bypassed back to suction before compression has begun, allowing the compressor to efficiently accommodate system requirements.

**Variable Volume Ratio** - A hydraulically actuated slide stop adjusts slide valve length to the most efficient of three possible volume ratios. This closely matches compressor volume ratio to system pressure ratio and minimizes the power penalties associated with under- or overcompression.

**Antifriction Bearings** - Cylindrical roller bearings handle radial loads and four-point angular contact ball bearings, aided by balance pistons (in some cases), absorb thrust loads. No preloading is required. At design conditions, L10 life is in excess of 100,000 hours. Roller bearings also maintain superior rotor positioning to minimize internal leakage and

provide excellent performance. System differential pressure is normally sufficient as the driving force to supply oil to the bearings, thereby eliminating the need for an oil pump. Antifriction bearings have lower frictional horsepower requirements for lower power consumption. Compressor housings are machined to provide static oil reservoirs for the bearings.

**Oil Injection** - Injected oil serves to lubricate the bearings, balance piston, and seal, fill any leakage paths between and around the rotors to prevent gas bypassing, and maintain superior efficiencies. Oil injection minimizes noise and vibration and keeps the compressor cool to prevent overheating by absorbing much of the heat from compression.

**Close-Coupled Motor** - XJF 95/120 model compressors are supplied with a C-flange adaptor. XJF 151 model compressors are available with a C-flange/D-flange adaptor as an option. This allows direct connection to a motor guaranteeing coupling alignment without requiring field labor.

**Made in the USA** - The entire compressor is designed and built in Waynesboro, PA. Expert engineering, automated machining centers, clean temperature controlled assembly, and stringent quality control requirements (ISO 9001) all contribute to assuring easy installation, reliable operation, and convenient servicing.

### MATERIALS OF CONSTRUCTION

**Castings** - ASTM A48 class 40 gray cast iron is standard for pressure-retaining parts. Suction and discharge flanges comply with ANSI B16.1. A 400 class suction and discharge is standard on all models. An alternate casing material is ASTM A536 grade 60-40-18 ductile (nodular) iron.

**Rotors** - AISI-1141 low carbon steel, machined from hot-rolled bar stock.

**Drive Shaft** - Jackshaft is made of AISI 1144 carbon steel.

**Gears** - 4140H steel, through hardened to 32-36 Rockwell "C". Nitride case hardened. ANSI/AGMA 2000 - A88 specifications.

**Bearings** - Rolling elements and rings are AISI-52100 medium carbon alloy steel. Cages are brass, polyamide, or steel. Tolerance quality complies with ABEC 1 through 3.

**Slide Valve Spindle** - AISI-1141 resulfurized, low carbon steel.

**Slide Valve & Slide Stop Indicators** - Type 304 stainless steel, bronze.

**Pistons, Spacers, Etc.** - Fabricated from class 40 gray cast iron.

**Retaining (Snap) Rings & Spring Washers** - High carbon spring steel.

**Bolts** - Grade 8.8, heat treated, medium carbon steel, socket head cap screws.

**Static Seals** - HNBR O-rings. Viton also available.

**Dynamic Seals** - Carbon filled teflon.

**Shaft Seal** - Spring-loaded, stationary, carbon end face with a stainless steel carrier against a rotating nonmagnetic cast iron alloy (Ni-resist) floating seat. The assembly is fully balanced and capable of sealing up to 350 PSIG but is vented to low pressure to extend seal life. Secondary seals are HNBR or viton o-rings. Alternate seal designs and materials are available for some applications.

### TYPICAL PERFORMANCE

| Model | R-507 (HCFC) |     |       |     | R-717 (Ammonia , NH <sub>3</sub> ) |     |       |     | Natural Gas (SG=.65, k=1.26) |       |       |    |
|-------|--------------|-----|-------|-----|------------------------------------|-----|-------|-----|------------------------------|-------|-------|----|
|       | Capacity     |     | Power |     | Capacity                           |     | Power |     | Capacity                     |       | Power |    |
|       | TR           | kW  | BHP   | kW  | TR                                 | kW  | BHP   | kW  | MMSCFD                       | MSCMH | BHP   | kW |
| 95S   | 52           | 183 | 71    | 53  | 51                                 | 181 | 62    | 46  | 0.153                        | 0.181 | 14    | 10 |
| 95M   | 30           | 105 | 43    | 32  | 32                                 | 111 | 38    | 28  | 0.094                        | 0.111 | 8     | 6  |
| 95L   | 38           | 135 | 54    | 40  | 39                                 | 138 | 47    | 35  | 0.117                        | 0.138 | 10    | 8  |
| 120S  | 107          | 375 | 145   | 108 | 104                                | 364 | 124   | 92  | 0.309                        | 0.365 | 27    | 20 |
| 120M  | 63           | 220 | 87    | 65  | 64                                 | 224 | 76    | 57  | 0.190                        | 0.224 | 17    | 13 |
| 120L  | 80           | 280 | 109   | 81  | 79                                 | 278 | 95    | 71  | 0.235                        | 0.277 | 21    | 16 |
| 151A  | 126          | 444 | 162   | 121 | 121                                | 425 | 143   | 107 | 0.373                        | 0.440 | 30    | 23 |
| 151M  | 152          | 534 | 193   | 144 | 143                                | 502 | 169   | 126 | 0.441                        | 0.520 | 36    | 27 |
| 151L  | 191          | 673 | 241   | 180 | 177                                | 622 | 210   | 156 | 0.546                        | 0.644 | 44    | 33 |
| 151N  | 231          | 813 | 293   | 219 | 211                                | 744 | 251   | 187 | 0.652                        | 0.769 | 53    | 40 |

**Notes:**

1. SG=Specific Gravity, k=Ratio of Specific Heats (Cp/Cv), TR=Tons Refrigeration, kW=Kilowatts, BHP=Brake Horsepower, MMSCFD=Millions Standard Cubic Feet per Day, MSCMH=Thousands Standard Cubic Meters per Hour.
2. R-507 ratings based on 20°F (-6.7°C) suction and 95°F (35°C) condensing with 10°F (5.5°C) liquid subcooling and 10°F (5.5°C) suction superheat at 3550 RPM.
3. R-717 ratings based on 20°F (-6.7°C) suction and 95°F (35°C) condensing with 10°F (5.5°C) liquid subcooling and 10°F (5.5°C) suction superheat at 3550 RPM.
4. Natural gas ratings based on 25 PSIA (172 kPaA), 80°F (27°C) suction and 75 PSIA (517 kPaA) discharge at 1750 RPM.

**MODEL NUMBER EXPLANATION**

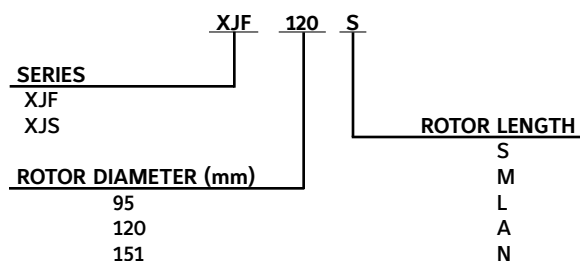

**DESIGN LIMITATIONS AND MECHANICAL CHARACTERISTICS**

|   | COMPRESSOR MODEL   |                              |                              |  |                              |                              |  |                              |                              |                              |
|---|--|------------------------------|------------------------------|--|------------------------------|------------------------------|--|------------------------------|------------------------------|------------------------------|
|   | 95S  | 95M                          | 95L                          | 120S   | 120M                         | 120L                         | 151A   | 151M                         | 151L                         | 151N                         |
| Approx Compr. Wt. lb (kg)   | XJS = 460 (209)<br>XJF = 660 (299)   |                              |                              | XJS = 670 (305)<br>XJF = 840 (380)                 |                              |                              | XJS = N/A<br>XJF = 1195 (542)                |                              |                              |                              |
| Rotor Dia. mm   | 95   |                              |                              | 120  |                              |                              | 151  |                              |                              |                              |
| Gear Ratio (Drive:Pinion)   | Male rotor driven by integral gear set   |                              |                              |  |                              |                              |  |                              |                              |                              |
|   | 66:31  | 55:42                        | 60:37                        | 66:31  | 55:42                        | 60:37                        | 51:46  | 55:42                        | 60:37                        | 64:33                        |
| Minimum Driver Speed <sup>(1)(2)</sup> RPM  | 600 <sup>(1)(2)</sup>  |                              |                              |  |                              |                              |  |                              |                              |                              |
| Maximum Driver Speed RPM  | 3550   | 5772                         | 4661                         | 3550   | 5772                         | 4661                         | 6297   | 5332                         | 4306                         | 3600                         |
| Max. Input Power to Rotor Shaft BHP (KW)  | 100 (75)   |                              |                              | 208 (155)  |                              |                              | 400 (298)                                    |                              |                              |                              |
| Min. Breakaway Torque ft-lb (Nm)  | 3 (4.1)  |                              |                              | 4 (5.4)  |                              |                              | 5 (6.8)                                      |                              |                              |                              |
| Mass Moment of Inertia <sup>(3)</sup> ft <sup>2</sup> -lb <sub>m</sub> (m <sup>2</sup> -kg) | .9<br>(.038) <sup>(3)</sup>  | .38<br>(.016) <sup>(3)</sup> | .55<br>(.023) <sup>(3)</sup> | 2.2<br>(.093) <sup>(3)</sup>                       | .88<br>(.037) <sup>(3)</sup> | 1.3<br>(.055) <sup>(3)</sup> | 2.7<br>(.114) <sup>(3)</sup>                 | 3.6<br>(.154) <sup>(3)</sup> | 5.4<br>(.228) <sup>(3)</sup> | 7.6<br>(.319) <sup>(3)</sup> |
| Suction Flange in. (mm)   | 2-1/2 (64)   |                              | 3 (96)                       | 4 (102) <sup>(4)</sup>                             |                              |                              | 5 (127)                                      |                              |                              |                              |
| Discharge Flange <sup>(5)</sup> in. (mm)  | XJS=Side XJF=Bottom<br>2-1/2 (64) <sup>(5)</sup>   |                              |                              | XJS=Side XJF=Side or Bot.<br>3 (76) <sup>(5)</sup> |                              |                              | XJS=N/A XJF=Bottom<br>4 (102) <sup>(5)</sup> |                              |                              |                              |
| Theoretical Displacement ft <sup>3</sup> /rev. (m <sup>3</sup> /rev.)                       | .040864<br>(.001157)   | .025134<br>(.000712)         | .031125<br>(.000881)         | .082343<br>(.002332)                               | .050648<br>(.001434)         | .062718<br>(.001776)         | .09623<br>(.002725)                          | .11366<br>(.003219)          | .14075<br>(.003986)          | .16833<br>(.004767)          |
| Displ. at 3550 rpm Driver Speed ft <sup>3</sup> /min (m <sup>3</sup> /hr)                   | 145<br>(247)   | 89<br>(152)                  | 111<br>(188)                 | 292<br>(497)                                       | 180<br>(306)                 | 223<br>(378)                 | 342<br>(580)                                 | 404<br>(686)                 | 500<br>(849)                 | 598<br>(1015)                |
| Displ. at 2950 rpm Driver Speed ft <sup>3</sup> /min (m <sup>3</sup> /hr)                   | 121<br>(205)   | 74<br>(126)                  | 92<br>(156)                  | 243<br>(413)                                       | 149<br>(234)                 | 185<br>(314)                 | 284<br>(482)                                 | 335<br>(570)                 | 415<br>(706)                 | 497<br>(844)                 |
| Displ. at 1750 rpm Driver Speed ft <sup>3</sup> /min (m <sup>3</sup> /hr)                   | 72<br>(122)  | 44<br>(75)                   | 54<br>(93)                   | 144<br>(245)                                       | 89<br>(151)                  | 110<br>(187)                 | 168<br>(286)                                 | 199<br>(338)                 | 246<br>(419)                 | 295<br>(501)                 |
| Displ. at 1450 rpm Driver Speed ft <sup>3</sup> /min (m <sup>3</sup> /hr)                   | 59<br>(101)  | 36<br>(62)                   | 45<br>(77)                   | 119<br>(203)                                       | 73<br>(125)                  | 91<br>(155)                  | 140<br>(237)                                 | 165<br>(280)                 | 204<br>(347)                 | 244<br>(415)                 |
| Capacity Control  | Infinitely adjustable from 100% to 25% by piston- or handwheel- (except 95) actuated slide valve |                              |                              |  |                              |                              |  |                              |                              |                              |
| Volume Ratio  | Variable in 3 steps: 2.2, 3.5, 5.0   |                              |                              |  |                              |                              |  |                              |                              |                              |
| Max. Inlet Press. psia (bara)   | 100 (6.9)  |                              |                              |  |                              |                              | 150 (10.3)                                   |                              |                              |                              |
| Max. Outlet Press. psia (bara) <sup>(7)</sup>   | 400 (27.6) <sup>(7)</sup>  |                              |                              |  |                              |                              |  |                              |                              |                              |
| Max. Outlet Press. psia (bara) <sup>(8)</sup>   | 600 (41.4) <sup>(8)</sup>  |                              |                              |  |                              |                              |  |                              |                              |                              |
| Minimum Inlet Temp. <sup>(6)</sup> °F (°C)  | -76 (-60) <sup>(6)</sup>   |                              |                              |  |                              |                              |  |                              |                              |                              |
| Maximum Inlet Temp. <sup>(6)</sup> °F (°C)  | 200 (93.3) <sup>(6)</sup>  |                              |                              |  |                              |                              |  |                              |                              |                              |
| Maximum Outlet Temp. <sup>(6)</sup> °F (°C)   | 250 (121) <sup>(6)</sup>   |                              |                              |  |                              |                              |  |                              |                              |                              |
| Maximum Temp. Dif. (Suct. to Disch.) °F (°C)  | 250 (121)  |                              |                              |  |                              |                              |  |                              |                              |                              |
| Max. Bearing Oil Supply Temp. °F (°C)   | 230 (110)  |                              |                              |  |                              |                              |  |                              |                              |                              |

1. Contingent upon compression ratio, bearing L10 limitations, oil viscosity, and other operating conditions.
2. Compressor suction flow may be zero at full unload slide valve position below 1800 RPM.
3. Does not include coupling. Resolved to drive shaft.
4. A 3 in. suction flange is installed on 120S compressors if operating at 1750 or 1450 rpm.
5. XJS and XJF discharge casings are interchangeable within a model size to allow selection of discharge flange orientation.
6. At compressor suction flange. Minimum evaporator temperature can be lower.
7. Standard ASTM A48 class 40 gray cast iron housing. Some models capable of higher pressures. Consult factory.
8. ASTM A536 grade 60-40-18 ductile iron housings. .

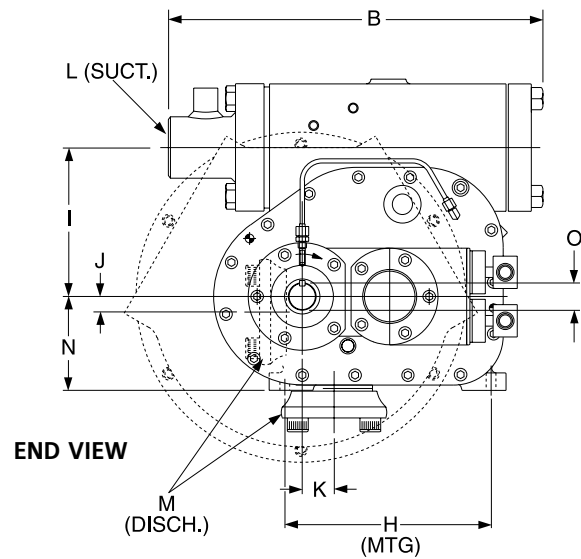
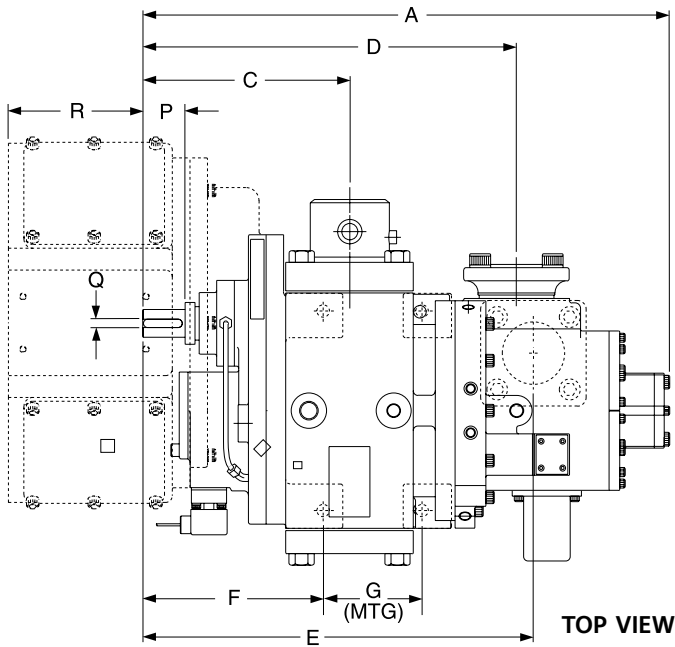

**NOTES:**

1. An XJS120 is shown for illustrative purposes only. Configurations of other compressor sizes vary slightly.
2. The suction connection may be moved to the other side.
3. The XJF151 has 3 pads instead of 4 feet for mounting.

**DIMENSIONAL OUTLINE**

| DIM | DESCRIPTION   | 95mm  |     | 120mm |     | 151mm |      |
|-----|---|-------|-----|-------|-----|-------|------|
|     |   | in    | mm  | in    | mm  | in    | mm   |
| A   | Compressor length (shaft end to bolt)               | 25.63 | 651 | 30.02 | 763 | 43.63 | 1108 |
| B   | Compressor width (stubout to bolt w/o sealing disk) | 22.94 | 583 | 23.37 | 594 | 29.23 | 743  |
| C   | Suction CL to shaft end                             | 10.87 | 276 | 11.77 | 299 | 19.56 | 497  |
| D   | Discharge CL (side) to shaft end                    | 18.57 | 472 | 21.27 | 540 | N/A   | N/A  |
| E   | Discharge CL (bottom) to shaft end                  | 18.44 | 468 | 21.90 | 556 | 31.10 | 790  |
| F   | Shaft end to rear mounting holes                    | 9.31  | 237 | 10.15 | 258 | 13.19 | 335  |
| G   | Mounting holes length between centers               | 4.06  | 103 | 5.62  | 143 | 12.56 | 319  |
| H   | Mounting holes width between centers, drive end     | 10.62 | 270 | 11.24 | 286 | 7.50  | 190  |
| H   | Mounting holes width between centers, nondrive end  | 10.62 | 270 | 11.24 | 286 | 2.25  | 57   |
| I   | Suction CL to shaft CL                              | 6.93  | 176 | 8.47  | 215 | 10.70 | 272  |
| J   | Discharge CL (side) to shaft CL                     | 1.38  | 35  | 0.97  | 25  | N/A   | N/A  |
| K   | Discharge CL (bottom) to shaft CL                   | 4.34  | 110 | 1.83  | 47  | 6.09  | 155  |
| L   | Suction diameter, S                                 | 2.50  | 64  | 3.00  | 76  | 5.00  | 127  |
| L   | Suction diameter, M                                 | 2.50  | 64  | 4.00  | 102 | 5.00  | 127  |
| L   | Suction diameter, L                                 | 3.00  | 76  | 4.00  | 102 | 5.00  | 127  |
| M   | Discharge diameter                                  | 2.50  | 64  | 3.00  | 76  | 4.00  | 102  |
| N   | Shaft CL to base                                    | 4.72  | 120 | 5.34  | 136 | 5.80  | 147  |
| O   | Shaft diameter                                      | 1.38  | 35  | 1.58  | 40  | 2.00  | 51   |
| P   | Shaft length available for coupling, XJS            | 2.02  | 51  | 2.42  | 62  | N/A   | N/A  |
| P   | Shaft length available for coupling, XJF            | 2.02  | 51  | 2.24  | 57  | 3.86  | 98   |
| Q   | Keyway width  | 0.39  | 10  | 0.47  | 12  | 0.50  | 13   |
| R   | Motor adapter length from shaft end                 | 6.87  | 175 | 7.48  | 190 | 8.13  | 207  |